

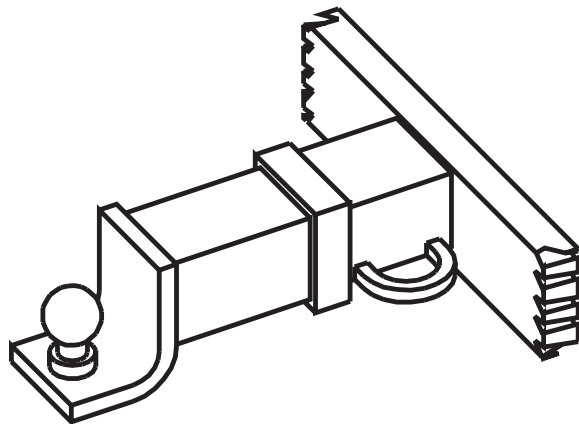

*Hitch Addendum*  
**2002**



The information printed here reflects product design, fabrication, and component parts at the date of printing. The manufacturer reserves the right, at any time, to make changes in product design or material or component specifications as its sole option, without notice. This includes the substitution of components of a different brand or trade name, which will result in comparable performance. All information printed in this document is subject to change after the date of printing.

Due to product improvements, changes during the model year and/or transcription errors that may occur, information represented within the owner's manual and/or this document may not be accurate at the time of your purchase. Please confirm any information with your dealer.

The following information supersedes the information published in the 2002 Roadmaster Chassis Manual on page 9, under "HITCH - Using the Rear Receiver." Please utilize the information provided henceforth.

**©Copyright Monaco Coach Corporation. All rights reserved. All trademarks or registered trademarks are property of their respective holders. Brand name products of other companies mentioned in this addendum are not endorsed by Monaco Coach Corporation.**

When using the rear hitch remember that the motorhome is intended for towing light loads. The motorhome is designed to be used primarily as a recreational vehicle, towing will affect durability and economy. Safety and satisfaction require proper receiver use. Avoid excessive loads or other misuse. Do not use the motorhome to tow anything until it has been driven 500 miles (800 kilometers). Weight pushing down on the rear hitch must not exceed 10% of the hitch capacity. It is recommended to weigh the motorhome when fully loaded to ensure proper weight distribution of the GCVW (gross combined vehicle weight). When weighing the motorhome add all passenger weight to the GCVW total. The motorhome fully loaded, and any vehicle or trailer towed by it, must not exceed the GCVW.

## HITCH - Using the Rear Receiver

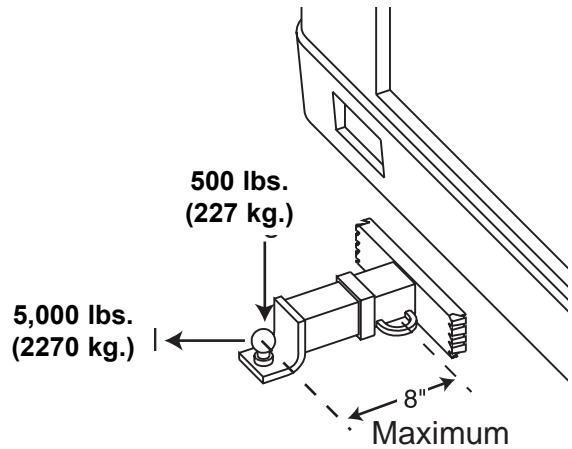

020065c



**WARNING: Any trailer being towed by a motorhome must have adequate brakes. Failure to follow these instructions will create a safety hazard and may result in an accident.**

### Tow Car or Trailer:

1. Connect tow car or trailer with light harness to motorhome and perform a light check.
2. Connect safety chains.
3. Check the tow car or trailer and the motorhome before starting a trip and at each rest stop.
4. Flat tires on a towed vehicle cannot be detected from the motorhome while driving. A flat tire is a safety hazard and may cause extensive damage. Check tires on the tow vehicle frequently.

ENGINE TYPE	RATED CAPACITY	TONGUE WEIGHT
ISB 210	5,000 lbs.	500 lbs.

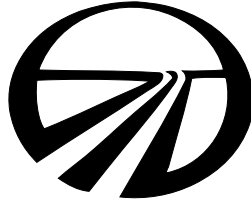

**MONACO COACH CORPORATION  
CHASSIS DIVISION**

**2700 S. Nappanee Street  
Elkhart, IN 46517**

**(219) 389-4113**

**800-866-6226**

